

METAGLAS® Sight glass for Sanitary Clamp Fitting

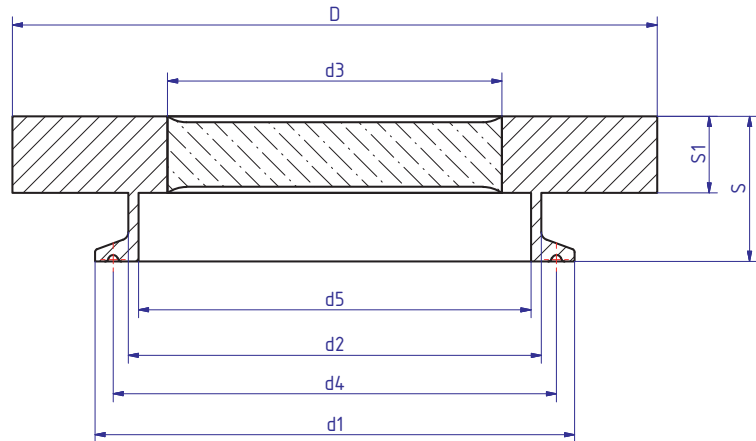
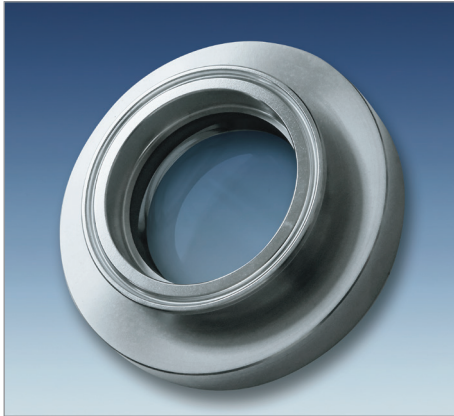

Applications

- For clamp fittings to
DIN32 676 / ISO 2852

Advantages

- Extremely compact construction
- Suitable for food processing & other sterile applications
- Reliability against total failure – the possibility of sudden unexpected rupture is totally excluded
- Fast & simple installation & maintenance
- Extreme resistance to impact and Temperature
- Wide acceptance in the European & American food, beverage, pharmaceutical and chemical industries
- Large view

Approvals and technical data

- Manufactured and tested in conformance with:
- Pressure Equipment Directive 2014/68/EU, Module H (DIN/EN/ISO 9001)
- AD 2000 Standards W0/TRD 100
- Sight glass fused to metal conforming to DIN 7079
- Borosilicate Glass to DIN 7080 / DIN 7079

Material certificates

- Certificate of Conformity to EN 10204-3.1 or 3.2

Operating conditions

- Pressure: -1 to 16 bar
- Temperature: see table

Ring

materials	Temperature (TS)
1.4462	-30°C bis +280°C
2.4602	-60°C bis +300°C

Nominal size		d1	d2	d3	d4	d5	S	S1	D	Max. operating pressure [bar]
DN	Zoll									
25/32/40	1", 1½"	50,5	38	33	43,5	34,8	22	10	65	16
50	2"	64	51	45	56,5	47,5	24	12	85	16
65	3"	91	76	65	83,5	72	34	19	125	16
100	4"	119	101	83	110,0	97,4	36	19	160	16
-	5"	144,5	127	95	134,5	123	36	18	180	10
-	6"	167	153	110	156,5	146,8	36	19	210	10
-	8"	217,5	202	140	207,4	198	40	20	280	10