

Sight Glass Fitting, Circular DIN28120

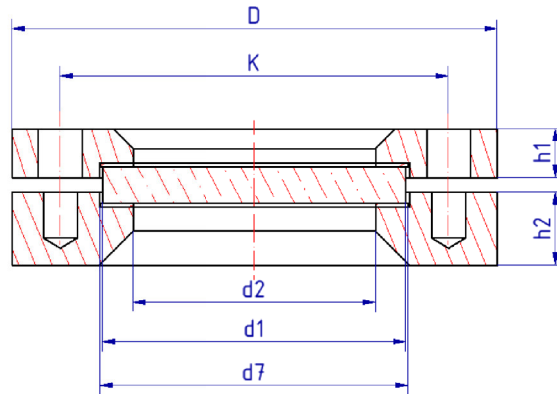
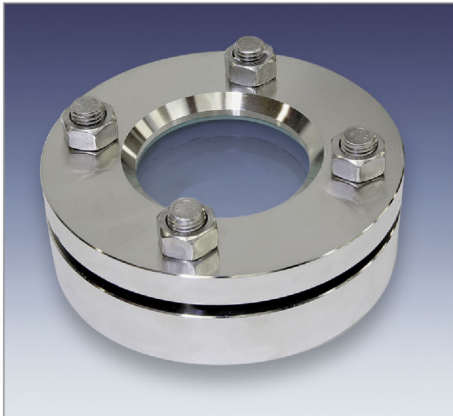

Application

- Sight glass fittings acc. to DIN 28120 are circular flanged ports for welding into and onto the vessel wall. The block and the cover flange are screwed together tightly, with the sight glass disc and an independent gasket at the upper and the lower flange positioned between them.

Operating pressure

- 10 bar and 16 bar, depending on the size
- vacuum is possible as a special design

Operating temperature

- max. 280° C with borosilicate glass DIN 7080
- max. 150° C with sodalime glass DIN 8902
- also depending on the gasket material selection

Certificate

- Depending on customer requirements and at extra cost, can be provided acc. to DIN EN 10204 3.1 or 3.2

Montage

- After welding the block flange into the vessel wall, the gaskets and the sight glass plate as well as the cover flange are placed in the sequence shown and fastened with the nuts against the block flange fitted with stud bolts. Operational safety of sight glass plates depends essentially on their proper installation (e.g. without scratches) (see DIN7080). In the case of metal-fused sight glass discs, the above instructions do not apply in full, since the bolt forces are transmitted via the metal ring of the counter flange.

Note

- The structure of toughened glass is such that any surface damage or stress caused by uneven forces can lead to catastrophic failure.

Parts	Materials
Base flange	Carbon steel Rst 37-2, Stainless Steel 1.457
Gaskets	Klingersil C-4400 o. other
Sight glass disc	<ul style="list-style-type: none"> • borosilicate glass DIN 7080 • sodalime glass DIN 8902 • METAGLAS® DIN 7079
Cover flange	Carbon steel Rst 37-2, Stainless Steel 1.457
Bolts/ Nuts	Carbon steel 5.6, stainless steel A2-70 or A4-70

Nominal bore		Sight glass disc			Flanges				Bots		Gaskets			tightening torque
DN	PN	d1	d2	s	d	k	h1	h2	Anz.	Gew.	d3	d1	d7	Nm
50	10/16	80	100	15/15	165	125	16	30	4	M16	18	80	102	28/32
80	10/16	100	125	15/20	200	160	20	30	8	M16	18	10	127	20/23
100	10/16	125	150	20/25	220	180	22	30	8	M16	18	125	152	26/30
125	10/16	150	175	20/25	250	210	25	30	8	M16	18	150	177	32/34
150	10/16	175	200	25/30	285	240	30	36	8	M20	22	175	202	47/54
200	10	225	250	30	340	295	35	36	8	M20	22	225	252	63